

Pump Data

Brand :	Gol Pump		
Model :	GPL - 332		
Head Rate :	53 FEET	Flow Rate:	69 GPM
Head Max:	80 FEET	Flow Max:	128 GPM
Head Min:	13 FEET	Flow Min :	5 GPM
RPM :	3450 rpm		
Normal Power P1 :	3 HP		
Fluid:	Water		
Fluid Temperature:	at about 25 °C		
Density:	water 997 kg/m ³		
Fluid Viscosity:	8.90 × 10 ⁻⁴ Pa·s		
With Float switch	NONE		
Self Priming	Submersible		
Delivery size	2" NPT		
Suction size	With Strainer		
Made in :	TAIWAN		

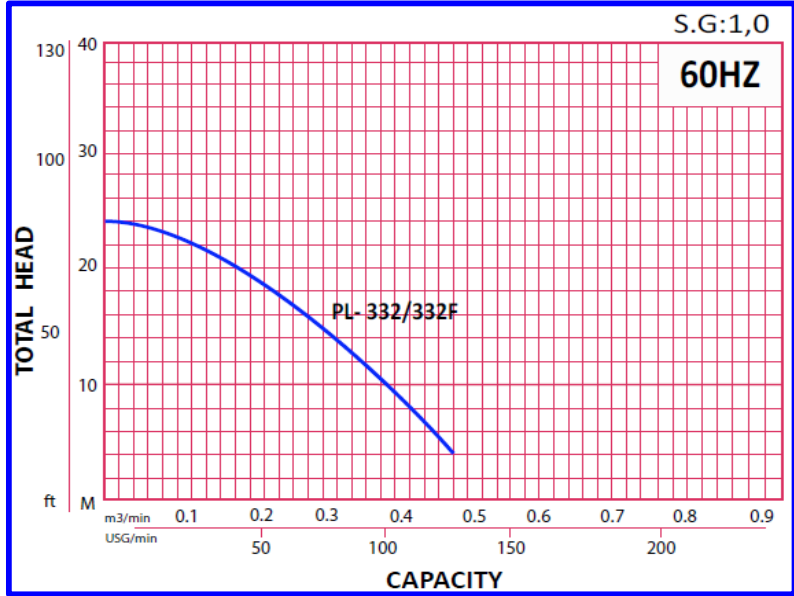

Motor Data

Power P2:	*		
Power P1:	2.2 KW		
Phase (PH):	3		
Rate Voltage :	480 V		
Capacitor Need :	*	µF	
Ferequency :	60 Hz		
Rated Speed (rpm):	3450 rpm		
Current (A):	3 A		
Cos φ :	0.85		
Degree of Protection (IP):	IP 68		
Safety Protection Included :	*		
length of Cable :	*	mm2×m	
Kind of Plug :	NONE		
Ambient Temp :	40°C = 104°F		



Other Pump Data

Impeller Size (mm) :	*		
Pressuer Rating :	PN 16		
Min. Fluid Temp :	0°C = 32°F		
Max. Fluid Temp :	90°C = 194°F		
Ambient Temp :	40°C = 104°F		
Humidity % :	100%		

Special Specification

Installation status :	Ver		
Variable frequency :	NONE		
Solid Passage	50	mm	

Materials

Pump Body :	Cast Iron		
Support:	FRPP		
Impeller	FRPP		
Mechanical Seal:	Teflon		
Rubber	NBR		
Pump Shaft:	SUS 304		
Strainer	FRPP		
outer cover:	Cast Iron		
Motor:	Cast Iron		

GPL-132/232/332/532
GPL-132F/232F/332F/532F

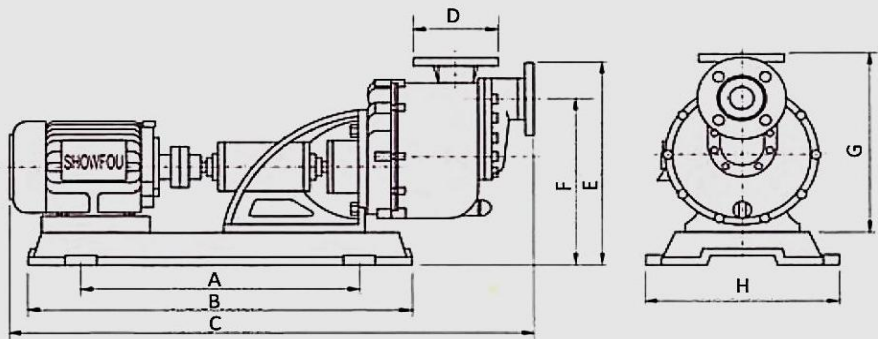

Shaft Seal

Type:	*		
Stationary Part	Ceramic		
Rotating Part	Carbon		
Elastomer	FRPP		

Pump and Motor specification optional

With Booster System	None		
With Complack	None		
Special Material	None		
Specail Voltage	None		

Protection system required

External Flout switch	*		
Minimum Starter	Starter SWT		

Weight : 45 Kg

Standard Approve



Applicant:

Wasted and Polluted Water Treatment PCB Electronic Industry Brick Kiln Industry Paper
Industry Leather Dyeing and Textile Surface Electric Plated Industry Chemical Engineering
Industry Medical and Pharmaceutical Industry and Food Industry High Temperature
and Chemical Liquid with Particles Can be used Limitedly such as Chemical Cuprem
Potassium Manganate Plating Gold Liquid and non-Electrolytic Nickel Plating Solvents Etc.

Dimension in

mm

A	520
B	780
C	1140
D	156
E	413
F	326
G	358
H	390