



Speedbox Duo

Wall-mounted pump driver for the control of two pumps at variable speed.

Single-phase or 3-phase pumps managed by two INVERTERS. Electric supply is single-phase 230V. Both pumps operate in cascade with alternated starting sequence.



Duo

OPERATING CHARACTERISTICS

- 2 inner inverters controlled by a single control for the management of 2 pumps.
- 2 operation modes: **duty-assist** and **duty-standby**.
- **ART function** (Automatic Reset Test). If the device has been stopped due to the action of the safety system against dry operation, the ART tries to connect the pump, with a programmed periodicity because the water supply could have been restored.
- **Automatic restore system** after an interruption of power supply. This system restores the previous mode keeping the configuration parameters.
- **Programmable electronic input**. It can be configured as: control of an external level detector, assignment of a second pressure setpoint or remote start-stop control.
- Volt-free contact for monitoring the alarms displayed in screen originated by irregularities or problems of the system.
- **STC function** (Smart Temperature Control): when temperature of electronic circuit is over 85 °C reduce automatically the frequency of the pump and decrease the generation of heat but keeping the flow of water.
- Input 4-20 mA for external pressure transducer.
- Control and information panel with LCD screen.
- External pressure transducer 0-10 bar, 0-16 bar or 0-25 bar with 4-20 mA input.
- Inner current sensor with instantaneous digital reading.
- **Register of operational parameters**. Information about: operating hours, counter of starts, counter of connections to the power supply.
- **Register of alarms**. Information about type and number of alarms.
- Open PID in the expert menu.



Low Voltage Directive 2014/35/EC
Electromagnetic Compatibility 2014/30/EC
RoHS 2011/65/EC + 2015/863/EC



TECHNICAL CHARACTERISTICS

	Duo
Power supply voltage	~1 x 230 Vac
Frequency	50/60 Hz
Max current pump 1	10 A (~3 x 230 Vac) ou 12A (~1 x 230 Vac)
Max current pump 2	10 A (~3 x 230 Vac) ou 12A (~1 x 230 Vac)
Max peak current	20% 10"
Range of set pressure	0,5 ÷ 25 bar
Protection degree	IP65
Input transducer	4-20 mA
Max environment temperature	50 °C
Net weight (without cables)	4,8 kg
Cooling system	Forced Convection
	i/o: ~1/~3

CONTROL PANEL

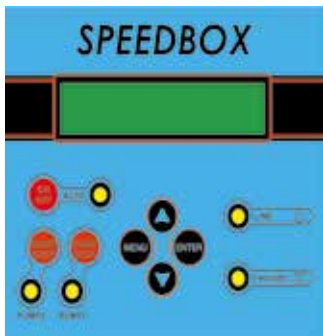

Control panel includes LCD screen, warning leds, push-buttons, START-STOP, AUTOMATIC and configuration system.

SAFETY SYSTEMS

- Control and safety system against overload.
- Electronic control and safety system against dry-running operation.
- Control and safety system against wrong supply voltage.
- Control and safety system against short-circuit between output phases

DIMENSIONS

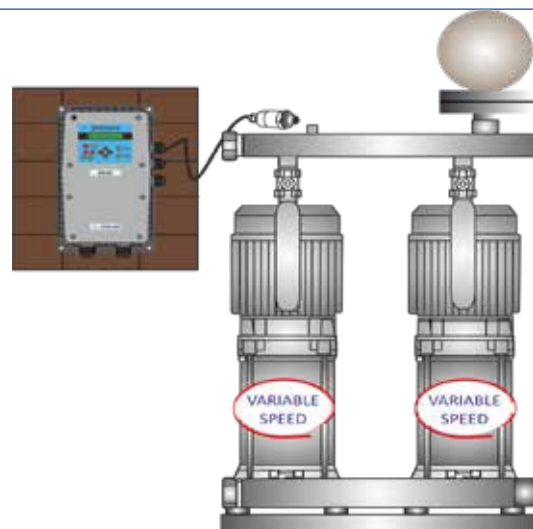
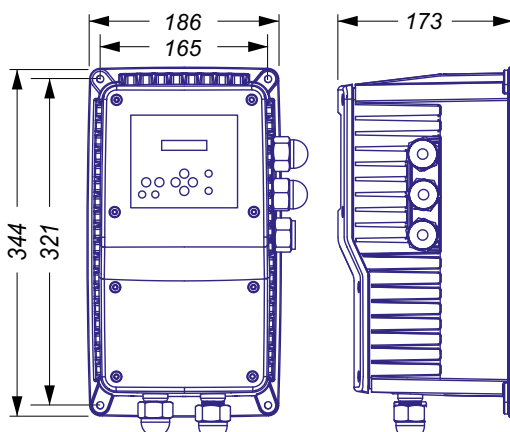



Gol Pumps Technology Company
Supply, Import, Export Water Pumps

Gol Pumps Technology

www.golpumps.com

Our Address: 6520 NW 77th CT, Miami FL 33166, USA

Sales DPT: +1 786 615 8984

After Sales Service: +1 786 452 9775

Fax: +1 786 615 7043

Email: info@golpumps.com

